

April 23, 2019 C:\Users\kha\Desktop\00042\Exhibits\2021-08-30 Park East PH 3 Assessment Area.dwg

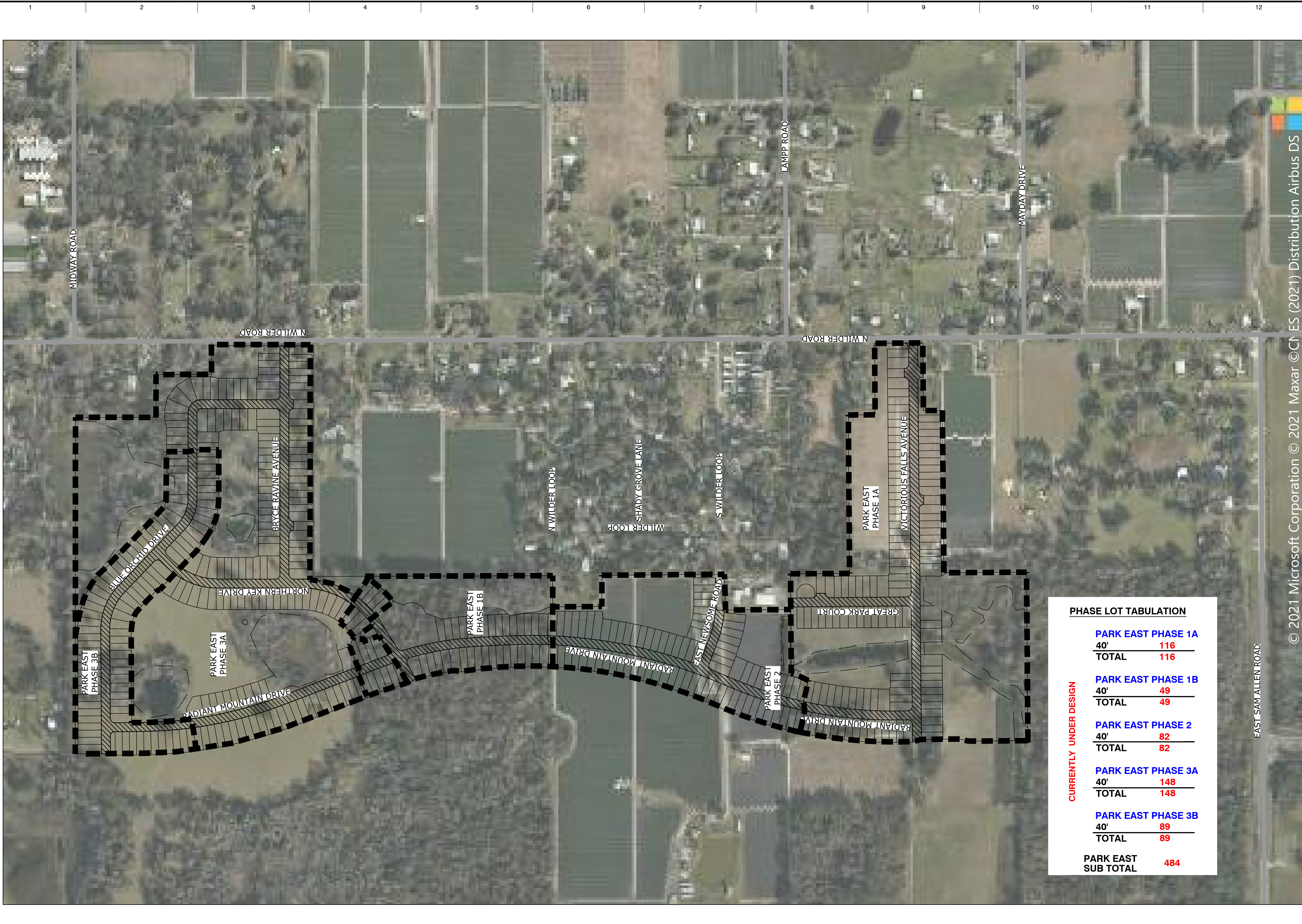

| PHASE LOT TABULATION | |
|-----------------------------|------------|
| PARK EAST PHASE 1A | |
| 40' | 116 |
| TOTAL | 116 |
| PARK EAST PHASE 1B | |
| 40' | 49 |
| TOTAL | 49 |
| PARK EAST PHASE 2 | |
| 40' | 82 |
| TOTAL | 82 |
| PARK EAST PHASE 3A | |
| 40' | 148 |
| TOTAL | 148 |
| PARK EAST PHASE 3B | |
| 40' | 89 |
| TOTAL | 89 |
| PARK EAST SUB TOTAL | 484 |

CURRENTLY UNDER DESIGN

EAST SAM ALLEN ROAD

© 2021 Microsoft Corporation © 2021 Maxar © CN ES (2021) Distribution Airbus DS

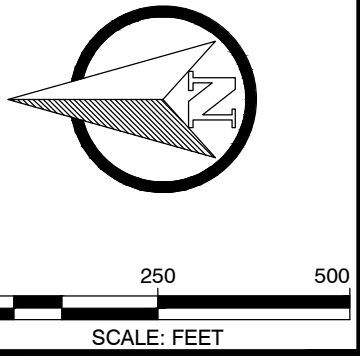

ARDURRA
 COLLABORATE. INNOVATE. CREATE.
 4921 Memorial Highway
 One Memorial Center, Suite 300
 Tampa, Florida 33634
 Phone: (813) 880-8881
 www.Ardurra.com
 License #2610

NORTH PARK ISLE DEVELOPMENT, LLC
 111 ARMENIA AVE. SUITE 201
 TAMPA, FLORIDA 33609

| NO. | DATE | REVISION | BY |
|-----|------|----------|----|
| | | | |
| | | | |
| | | | |
| | | | |
| | | | |
| | | | |
| | | | |
| | | | |
| | | | |
| | | | |
| | | | |

PARK EAST
 ASSESSMENT AREA EXHIBIT

JOB NO: 00042-2020-5301
 DATE: 11/30/2020

1 OF 1

8/6/2021